

NSAI

ECE TYPE-APPROVAL CERTIFICATE



Communication concerning:² Approval granted
 Approval extended
 Approval refused
 Approval withdrawn
 Production definitely discontinued

of a type of CNG/LNG component pursuant to Regulation No. 110.

Approval No: E24*110R05/00*0086*00

1. CNG/LNG component considered:
 - Container(s) or cylinder(s)²
 - Tank(s) or vessel(s)²
 - CNG accumulator(s)²
 - Pressure indicator²
 - Pressure relief valve²
 - Automatic valve(s)²
 - Excess flow valve²
 - Gas tight housing²
 - Pressure regulator(s)²
 - Non return valve(s) or check valve(s)²
 - Pressure relief device (PRD) (temperature triggered)²
 - Manual valve²
 - Flexible fuel lines²
 - Filling unit or receptacle²
 - Gas injector(s)²
 - CNG Compressor²
 - Gas flow adjuster²
 - Gas/air mixer²
 - Electronic control unit²
 - Pressure and temperature sensor(s)²
 - CNG filter(s)²
 - PRD (pressure triggered)²
 - Fuel rail²
 - Heat exchanger(s) / vaporizer(s)²
 - Natural gas detector(s)²
 - LNG filling receptacle(s)²
 - LNG pressure control regulator(s)²
 - LNG pressure and/or temperature sensor(s)²
 - LNG manual valve(s)²
 - LNG automatic valve(s)²
 - LNG non return valve(s)²
 - LNG pressure relief valve(s)²
 - LNG excess flow valve(s)²
 - LNG fuel pump(s)²

Type: DK-Lok Filter

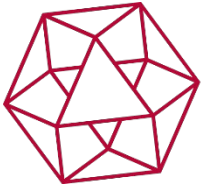

NSAI

Approval No: E24*110R05/00*0086*00

2. Trade name or mark: **DK-Lok Corporation**
3. Manufacturer's name and address: **DK-Lok Corporation
7, Golden root-ro 129beon-gil,
Juchon-myeon Gimhae-si,
Gyeongsangnam-do 50969
Republic of Korea**
4. If applicable, name and address of manufacturer's representative: **N/A.**
5. Submitted for approval on: **28.09.2023**
6. Technical service responsible for conducting approval tests: **TÜV SÜD Auto Service
10040 Mesa Rim Road
San Diego, CA 92121
USA**
7. Date of report issued by that service: **11.09.2023**
8. No. of report issued by that service: **23-00023-IS-MUC-00**
9. Approval granted/ ~~refused~~/ ~~extended~~/ ~~withdrawn~~²: **Granted**
10. Reason(s) of extension (if Applicable): **N/A.**
11. Place: **Dublin.**
12. Date: **10th October, 2023.**
13. Signature: 
14. The documents filed with the application or extension of approval can be obtained upon request.



¹ Distinguishing number of the country which has granted/extended/refused/withdrawn approval (see approval provisions in the Regulation).

² Strike out what does not apply.

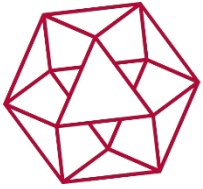

NSAI

Approval No: E24*110R05/00*0086*00

Annex 2B – Addendum

1. Additional information concerning the type approval of a type of CNG/LNG components pursuant to Regulation No. 110

1.1	Container(s) or cylinder(s)	
1.1.1	Dimensions:	<i>N/A</i>
1.1.2	Material:	<i>N/A</i>
1.1.2.	Tank(s) or vessel(s) (for LNG system)	
1.1.2.1.	Capacity:	<i>N/A</i>
1.1.2.2.	Material:	<i>N/A</i>
1.1.3.	CNG accumulator	
1.1.3.1.	Dimensions:	<i>N/A</i>
1.1.3.2.	Material:	<i>N/A</i>
1.1.3.3.	Capacity:	<i>N/A</i>
1.2.	Pressure indicator	
1.2.1.	Working pressure(s): ¹	<i>N/A</i>
1.2.2.	Material:	<i>N/A</i>
1.3.	Pressure relief valve (discharge valve)	
1.3.1.	Working pressure(s): ¹	<i>N/A</i>
1.3.2.	Material:	<i>N/A</i>
1.32.	CNG Compressor	
1.32.1.	Working pressure(s): ¹	<i>N/A</i>
1.32.2.	Material:	<i>N/A</i>
1.4.	Automatic valve(s)	
1.4.1.	Working pressure(s): ¹	<i>N/A</i>
1.4.2.	Material:	<i>N/A</i>
1.5.	Excess flow valve	
1.5.1.	Working pressure(s): ¹	<i>N/A</i>
1.5.2.	Material:	<i>N/A</i>
1.6.	Gas-tight housing	
1.6.1.	Working pressure(s):	<i>N/A</i>
1.6.2.	Material:	<i>N/A</i>
1.7.	Pressure regulator(s)	
1.7.1.	Working pressure(s): ¹	<i>N/A</i>
1.7.2.	Material:	<i>N/A</i>
1.8.	Non-return valve(s) or check valve(s)	
1.8.1.	Working pressure(s): ¹	<i>N/A</i>
1.8.2.	Material:	<i>N/A</i>

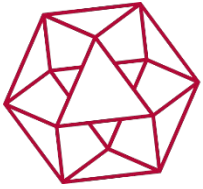

NSAI

Approval No: E24*110R05/00*0086*00

1.9.	Pressure relief device (temperature triggered)	
1.9.1.	Working pressure(s): ¹	<i>N/A</i>
1.9.2.	Material:	<i>N/A</i>
1.10.	Manual valve	
1.10.1.	Working pressure(s): ¹	<i>N/A</i>
1.10.2.	Material:	<i>N/A</i>
1.11.	Flexible fuel lines	
1.11.1.	Working pressure(s): ¹	<i>N/A</i>
1.11.2.	Material:	<i>N/A</i>
1.12.	Filling unit or receptacle	
1.12.1.	Working pressure(s): ¹	<i>N/A</i>
1.12.2.	Material:	<i>N/A</i>
1.13.	Gas injector(s)	
1.13.1.	Working pressure(s): ¹	<i>N/A</i>
1.13.2.	Material:	<i>N/A</i>
1.14.	Gas flow adjuster	
1.14.1.	Working pressure(s): ¹	<i>N/A</i>
1.14.2.	Material:	<i>N/A</i>
1.15.	Gas/air mixer	
1.15.1.	Working pressure(s): ¹	<i>N/A</i>
1.15.2.	Material:	<i>N/A</i>
1.16.	Electronic control unit	<i>N/A</i>
1.16.1.	Basic software principles:	<i>N/A</i>
1.17.	Pressure and temperature sensor(s)	
1.17.1.	Working pressure(s): ¹	<i>N/A</i>
1.17.2.	Material:	<i>N/A</i>
1.18.	CNG filter(s)	
1.18.1.	Working pressure(s): ¹	274 bar @ 120°C
1.18.2.	Material:	SS 316
1.19.	PRD (pressure triggered)	
1.19.1.	Working pressure(s): ¹	<i>N/A</i>
1.19.2.	Material:	<i>N/A</i>
1.20.	Fuel rail(s)	
1.20.1.	Working pressure(s): ¹	<i>N/A</i>
1.20.2.	Material:	<i>N/A</i>

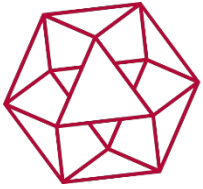

Approval No: E24*110R05/00*0086*00

1.21.	Heat Exchanger(s) / Vaporizer(s)	
1.21.1.	Working pressure(s): ¹	N/A
1.21.2.	Material:	N/A
1.22.	Natural gas detector(s):	
1.22.1.	Working pressure(s): ¹	N/A
1.22.2.	Material:	N/A
1.23.	LNG filling receptacle(s)	
1.23.1.	Working pressure(s): ¹	N/A
1.23.2.	Material:	N/A
1.24.	LNG pressure control regulator(s)	
1.24.1.	Working pressure(s): ¹	N/A
1.24.2.	Material:	N/A
1.25.	LNG pressure and/or temperature sensor(s)	
1.25.1.	Working pressure(s): ¹	N/A
1.25.2.	Material:	N/A
1.26.	LNG manual valve(s)	
1.26.1.	Working pressure(s): ¹	N/A
1.26.2.	Material:	N/A
1.27.	LNG automatic valve(s)	
1.27.1.	Working pressure(s): ¹	N/A
1.27.2.	Material:	N/A
1.28.	LNG non-return valve(s)	
1.28.1.	Working pressure(s): ¹	N/A
1.28.2.	Material:	N/A
1.29.	LNG pressure relief valve(s)	
1.29.1.	Working pressure(s): ¹	N/A
1.29.2.	Material:	N/A
1.30.	LNG excess flow valve(s)	
1.30.1.	Working pressure(s): ¹	N/A
1.30.2.	Material:	N/A
1.31.	LNG fuel pump(s)	
1.31.1.	Working pressure(s): ¹	N/A
1.31.2.	Material:	N/A

¹ Specify the tolerance

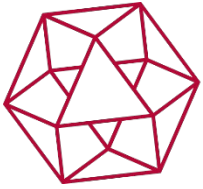

NSAI

Approval No: E24*110R05/00*0086*00

Index to the Information Package

Date of issue: *10th October, 2023.*

Date of latest amendment: *N/A.*

Reason for extension/revision: *N/A*

1. Additional conditions, and advisory notes on legal alternatives.

2. Test report(s)

- numbers(s): *23-00023-IS-MUC-00*

- date of issue: *11.09.2023*

- date of latest amendment: *N/A*

3. Information document

- number(s): *Essential Characteristics of the CNG-Component
acc. Annex 1A of ECE R 110*

- date of issue: *11.09.2023*

- date of latest amendment: *N/A*

Documentation: *24 pages*



Approval No: E24*110R05/00*0086*00

Appendix: **Additional conditions, and advisory notes on legal alternatives**

A: Additional conditions:

1. The attached technical report, with any of its attachments, forms part of this Type Approval certificate.
2. Each type from series production shall be to the measurements specified in the attached drawings, and shall be manufactured only from the materials specified in the Approval documents.
3. Changes in the type are permitted only with the explicit permission of NSAI. Breaches of this requirement will lead to a withdrawal of the Type Approval, and in addition may be subject to criminal prosecution.
4. At regular intervals, any tests or associated checks prescribed by the applicable legislation to verify continued conformity with the approved type shall be carried out. The manufacturer shall demonstrate compliance with this by submitting to NSAI evidence of adequate arrangements and documented control plans for each type approved.
5. Any set of samples or test pieces showing evidence of non-conformity shall give rise to further sampling and testing and all steps shall be taken to restore conformity of production.
6. This Type Approval will expire when it is surrendered by the holder, or withdrawn by NSAI, or when the approved type no longer conforms to legal requirements. The recall of the Type Approval can be issued by NSAI when the conditions required for the issuing or continuation of the Type Approval are no longer current, or when the Approval holder is in breach of the duties attached to the Type Approval, or when it is established that the approved type no longer meets the requirements of traffic safety.
7. Changes in the company name, address or manufacturing site, as well as in any of the sales or other agents specified in the issuing of the approval must immediately be notified to NSAI.
8. The duties imposed by the issuing of this certificate are not transferable. The legal protection of third parties is not affected by this certificate.
9. When the manufacture or sale of the system, component or separate technical unit has not been started within one year of the date of issue of this certificate, then NSAI is to be informed. This requirement also applies when the manufacture or sale has been halted for more than one year, or when it ought to have been halted for more than one year. The initial commencement of manufacture or sale, or the resumption of manufacture or sale, shall then be notified to NSAI within one month of commencement or resumption.

B: Legal Options:

Any objection to the requirements set out in this certificate shall be made within one month of the date of issue. The objection shall be made, in writing, to NSAI in Dublin.



Technical Report No.:	23-00023-IS-MUC-00	2023.09.11
Manufacturer:	DK-Lok Corporation	USA-AF
Type:	DK-Lok Filter	Page 1 of 4

TEST REPORT

23-00023-IS-MUC-00

About the Tests of CNG Filter for CNG-Vehicles

According to:

ECE-Regulation No. 110

UNIFORM PROVISIONS CONCERNING THE APPROVAL OF:

- I. SPECIFIC COMPONENTS OF MOTOR VEHICLES USING COMPRESSED NATURAL GAS (CNG) OR/AND LIQUIFIED NATURAL GAS (LNG) IN THEIR PROPULSION SYSTEM;

- II. VEHICLES WITH REGARD TO THE INSTALLATION OF SPECIFIC COMPONENTS OF AN APPROVED TYPE FOR THE USE OF COMPRESSED NATURAL GAS (CNG) OR/AND LIQUIFIED NATURAL GAS (LNG) IN THEIR PROPULSION SYSTEM

Revision 6 – amendment 4

05 series of amendments

Approval status	
<input checked="" type="checkbox"/>	Granting of a type approval – E24 110R05/00*0086 “C”
<input type="checkbox"/>	Extension/correction to type approval no. – N/A



Technical Report No.:	23-00023-IS-MUC-00	2023.09.11
Manufacturer:	DK-Lok Corporation	USA-AF
Type:	DK-Lok Filter	Page 2 of 4

0 Reason of Extension:

N/A. New type approval.

I General and Description

The Specific Component:

1.	CNG-component considered:	CNG Filter
2.	Make:	DK-Lok Corporation
3.	Type: Variant(s):	DK-Lok Filter V76 Series
4.	Name and address of the manufacturer:	DK-Lok Corporation 7, Golden root-ro 129beon-gil, Juchon-myeon Gimhae-si, Gyeongsangnam-do 50969 Republic of Korea
5.	Name and Address of Manufacturing plant:	Same as manufacturer above
6.	Operating Conditions:	Maximum Service Pressure: 200 bar @ 15°C
		Maximum Working Pressure: 274 bar @ 120°C – Class 6
		Operating Temperatures: -40°C to +120°C
7.	Drawings:	Various. See description in Annex 2

was tested according to the requirements of the mentioned test basis.

Technical Report No.:	23-00023-IS-MUC-00	2023.09.11
Manufacturer:	DK-Lok Corporation	USA-AF
Type:	DK-Lok Filter	Page 3 of 4

II Information Folder

This Test Report is based on the following information:

- Application for a new type approval by DK-Lok Corporation, dated 2023.08.06 (file: VG2023.09.11_DK-Lok Corporation_23-00023-IS-MUC-00_Application)
- Declaration by the Manufacturer, dated 2023.08.06 (file: D02023.09.11_DK-Lok Corporation_23-00023-IS-MUC-00_decl. by manuf)
- Essential Characteristics acc. to ECE R 110, Annex 1A (file: BB2023.09.11_DK-Lok Corporation_23-00023-IS-MUC-00_Annex 1A).

III Test Samples, Performed Tests and Test Results

The test samples, the performed tests, and the test results are described and summarized in *Annex 3 – DK-Lok Filter test samples* (file: DO2023.09.11_DK-Lok Corporation_23-00023-IS-MUC-00_Test samples) and *Annex 1 – DK-Lok Filter test results* (file: PB2023.09.11_DK-Lok Corporation_23-00023-IS-MUC-00_Test results).

The DK-Lok Components scope of approval includes all Variants listed in the present report in the various configurations as depicted in *Annex 4 – DK-Lok Filter catalogs* (file DO2023.09.11_DK-Lok Corporation_23-00023-IS-MUC-00_Catalogs).

IV Approval History

Overview of the variants / extensions for the Type DK-Lok Components – Class 6.

	Type	Variant(s)	Content of Extension(s)	MAWP (bar)	Temp (°C)	Report No. and Date
Initial testing	DK-Lok Filter	V76 Series	N/A	274	-40 to +120	Annex 1_23-00023-IS-MUC-00 dated 2023.09.11



Technical Report No.:	23-00023-IS-MUC-00	2023.09.11
Manufacturer:	DK-Lok Corporation	USA-AF
Type:	DK-Lok Filter	Page 4 of 4

V Statement of conformity

The information folder as mentioned under item II and the type described therein are in compliance with the test specification mentioned above. The worst-case was selected in accordance with document “Preparation of Test Reports”.

The test report may be reproduced and published in full and by the client only. It can only be reproduced partially with the written permission of the test laboratory.

Test report no. 23-00023-IS-MUC-00 and the previous test reports issued by the Technical Service of TÜV SÜD Auto Service GmbH plus all documents and measurement results necessary for evaluation had been submitted. The above test reports continue to apply to the type of vehicle/vehicle component. This test report provides a summary of, and covers the full scope of, type testing, including the documentation of the vehicle/vehicle component.

TÜV SÜD Auto Service GmbH is designated as Technical Service by:

Approval authority	Country	Registration-number
Kraftfahrt-Bundesamt (KBA)	Germany	KBA-P 00100-10
Vehicle Certification Agency (VCA)	United Kingdom	VCA-TS-006
Approval Authority of the Netherlands (RDW)	The Netherlands	RDWT-082-xx
National Standards Authority of Ireland (NSAI)	Ireland	Technical Service Number: 49
Vehicle Safety Certification Center (VSCC)	Taiwan/Taiwan	DE04-06-2
Société Nationale de Certification et d'Homologation S.A.	Luxembourg	13/B(g)

San Diego, California USA
 2023.09.11.



André Frégeau
 The Authorized Signatory

Annexes:

- Annex 1 – DK-Lok Filter test results
- Annex 2 – DK-Lok Filter drawings
- Annex 3 – DK-Lok Filter test samples
- Annex 4 – DK-Lok Filter catalogs
- Annex 5 – DK-Lok Filter service instructions.

Annex 1 – DK-Lok Filter test results

Test Report



Auto Service

Test Report No.: Annex 1 – 23-00023-IS-MUC-00
 Manufacturer: DK-Lok Corporation
 Component / Type: CNG Filter / DK-Lok Filter

2023.09.11
 USA-AF
 Page 1 of 6

Test Results:

ECE R-110	Test Procedure	Test Sample	Requirement	Test Result	Remarks
Annex 5A	Overpressure	3X CNG Filter of each Variant described in Annex 3 of this report	No visible evidence of rupture or distortion at 1,5 times the working pressure for 3 minutes at ambient temperature	OK No rupture or distortion at 1,5 X 274 bar = 411 bar	At hand.
Annex 5B	External leakage	3X CNG Filter of each Variant described in Annex 3 of this report	Leakage <15cm ³ /h at 20°C at -40°C at +120°C Conditioning time of 8 hours Leakage pressure hold of 3 minutes	OK No leakage at ambient, -40°C, and +120°C from 0 to 411 bar	At hand.
Annex 5C	Internal leakage	3X CNG Filter of each Variant described in Annex 3 of this report	Leakage <15cm ³ /h at 20°C at -40°C at +120°C Conditioning time of 8 hours Leakage pressure hold of 3 minutes	OK No leakage at ambient, -40°C, and +120°C from 0 to 411 bar	At hand.

Test Report



Auto Service

Test Report No.: Annex 1 – 23-00023-IS-MUC-00
 Manufacturer: DK-Lok Corporation
 Component / Type: CNG Filter / DK-Lok Filter

2023.09.11
 USA-AF
 Page 2 of 6

ECE R-110	Test Procedure	Test Sample	Requirement	Test Result	Remarks
Annex 5D	CNG Compatibility	Non-metallic specimens tested (5 samples each) 1) NBR N8614AA 2) HNBR H7000AA 3) EPDM E7050-AA 4) KETRON PK1000 5) PTFE TF1641 6) ITAflon IT-1-10S	Resistance to n-pentane according to ISO 1817 for 72 hours while at 23°C. a) Max. change in volume: 20% b) Max mass decrease: < 5%	OK The change of volume or weight observed on all materials are within the requirements 1-a) -1,12% 1-b) -2,55% 2-a) -1,03% 2-b) -2,25% 3-a) -5,29% 3-b) -4,47% 4-a) -0,16% 4-b) -0,30% 5-a) -0,20% 5-b) 0,27% 6-a) -2,78% 6-b) 0,52%	At hand.

Test Report



Auto Service

Test Report No.: Annex 1 – 23-00023-IS-MUC-00
 Manufacturer: DK-Lok Corporation
 Component / Type: CNG Filter / DK-Lok Filter

2023.09.11
 USA-AF
 Page 3 of 6

ECE R-110	Test Procedure	Test Sample	Requirement	Test Result	Remarks
Annex 5E	Corrosion Resistance	3X Filter of each Variant described in Annex 3 of this report	ISO 15500-2 salt spray for 144 hours with all connections closed. Leak free according to Annex 5B+C	OK Leak free. Components remained fully functional	At hand.
Annex 5F	Resistance to Dry Heat	Non-metallic specimens tested (5 samples each) 1) NBR N8614AA 2) HNBR H7000AA 3) EPDM E7050-AA 4) KETRON PK1000 5) PTFE TF1641 6) ITAflon IT-1-10S	Air exposure of non-metallic samples to +120°C for 168 hours per ISO 188 a) Δ -tensile strength: < +25% b) Δ -ultimate elongation: < +10 %, < -30 %	OK 1-a) -7,13% 1-b) -3,16% 2-a) -1,25% 2-b) -1,55% 3-a) 8,22% 3-b) -22,88% 4-a) 16,64% 4-b) -20,03% 5-a) -11,45% 5-b) -16,28% 6-a) -1,02% 6-b) 2,04%	At hand.

Test Report



Auto Service

Test Report No.: Annex 1 – 23-00023-IS-MUC-00
 Manufacturer: DK-Lok Corporation
 Component / Type: CNG Filter / DK-Lok Filter

2023.09.11
 USA-AF
 Page 4 of 6

ECE R-110	Test Procedure	Test Sample	Requirement	Test Result	Remarks
Annex 5G	Ozone Ageing	Non-metallic specimens tested (5 samples each) 1) NBR N8614AA 2) HNBR H7000AA 3) EPDM E7050-AA 4) KETRON PK1000 5) PTFE TF1641 6) ITAflon IT-1-10S	No cracking allowed	OK None of the samples exhibited signs of cracking	At hand.
Annex 5L & Annex 4C	Durability	3X CNG Filter of each Variant described in Annex 3 of this report	Leak free according to Annex 5B after gas cycling from 0 to 200 bar; 19200 cycles at ambient with air, and 400 cycles at each -40°C and +120°C with GN2	OK Leak free. Components remained fully functional post testing and able to open/close with a torque less than the maximum allowed	At hand.
Annex 5N	Vibration resistance	3X CNG Filter of each Variant described in Annex 3 of this report	Vibrate for 2 hours at 17Hz with amplitude of 1,5mm in each three axis for a total of 6 hours Leak free according to Annex 5C after vibration	OK No damage. Leak free. Components remained fully functional post testing	At hand.

Test Report



Auto Service

Test Report No.: Annex 1 – 23-00023-IS-MUC-00
 Manufacturer: DK-Lok Corporation
 Component / Type: CNG Filter / DK-Lok Filter

2023.09.11
 USA-AF
 Page 5 of 6

ECE R-110	Test Procedure	Test Sample	Requirement	Test Result	Remarks
Annex 5O	Operating Temperature	3X CNG Filter of each Variant described in Annex 3 of this report	Components to be fully functional to operate from -40°C to +120°C	OK Components remained fully functional and leak free at ambient, -40°C, and +120°C from 0 to 411 bar	At hand.

The non-metallic materials tested and approved for the CNG DK-Lok Filter Variant(s) listed in the test report 23-00023-IS-MUC-00 are the following:

- 1) NBR N8614AA, 90 +/-5 Shore A, manufactured by GE MAO Rubber Industrial Co., LTD
- 2) HNBR H7000AA, 70 +/-5 Shore A, manufactured by GE MAO Rubber Industrial Co., LTD
- 3) EPDM E7050-AA, 70 +/-5 Shore A, manufactured by GE MAO Rubber Industrial Co., LTD
- 4) KETRON PK1000, >100 HRM, manufactured by Mitsubishi Chemical Advanced Materials Korea, LTD
- 5) PTFE TF1641, >56 HRD, manufactured by 3M Advanced Materials Division
- 6) ITAflon IT-1-10S, >60 HRD, manufactured by ITAflon S.r.l..

Test Report



Auto Service

Test Report No.:	Annex 1 – 23-00023-IS-MUC-00	2023.09.11
Manufacturer:	DK-Lok Corporation	USA-AF
Component / Type:	CNG Filter / DK-Lok Filter	Page 6 of 6

Testing was performed in the following laboratories under supervision of the TÜV SÜD Auto Service GmbH inspector: #1878224 (Overpressure, External & Internal Leakage, CNG Compatibility, Resistance to Dry Heat, Ozone Ageing, Durability, Operating Temperature); #2238319 (Vibration); #1913520 (Corrosion Resistance).

The measurement uncertainties were considered according to the test basis and the Process Description of TÜV SÜD Auto Service “AS-AM-PB-CRC-006”. The technical expert confirms that the tests have been performed as required by ECE Regulation No. 110 and have yielded the results as described above.

San Diego, CA USA
2023.09.11

The Technical Expert and Signatory
André Frégeau.



DK-Lok Corporation / DK-Lok Filter

Essential Characteristics of the CNG-Component acc. Annex 1A of ECE R 110	
Name and address of the manufacturer:	DK-Lok Corporation 7, Golden root-ro 129beon-gil, Juchon-myeon Gimhae-si, Gyeongsangnam-do 50969 Republic of Korea
Name and address of the manufacturing plant:	DK-Lok Corporation 7, Golden root-ro 129beon-gil, Juchon-myeon Gimhae-si, Gyeongsangnam-do 50969 Republic of Korea
Test Specification:	ECE-Regulation No. 110 with the 05 series of amendments – date of entry into force of 22 June 2022
1.2.4.5.13. CNG filter:	Yes
1.2.4.5.13.1. Make(s):	DK-Lok Corporation
1.2.4.5.13.2. Type(s):	DK-Lok Filter Variant(s): V76 Series
1.2.4.5.13.3. Description:	Filter for CNG V76 Series (ECER110) Rev. 0
1.2.4.5.13.4. Working pressure(s):	274 bar @ 120°C
1.2.4.5.13.5. Material:	SS 316
1.2.4.5.13.6. Operating temperatures:	-40°C to 120°C

André Segean
2023.09.11.



Annex 2 – DK-Lok Filter drawings

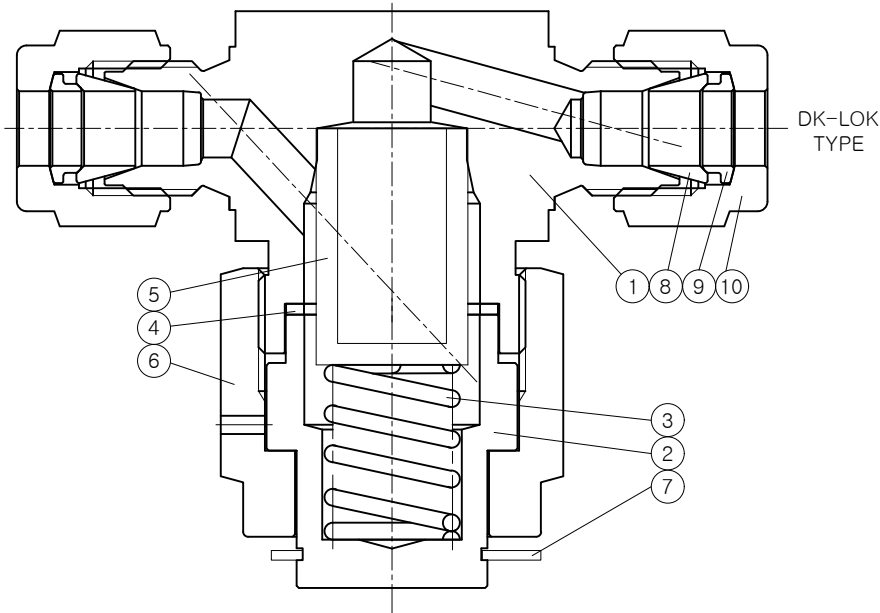

MARKING

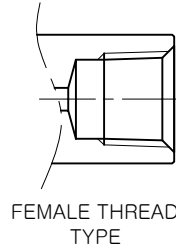
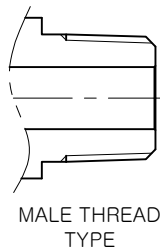
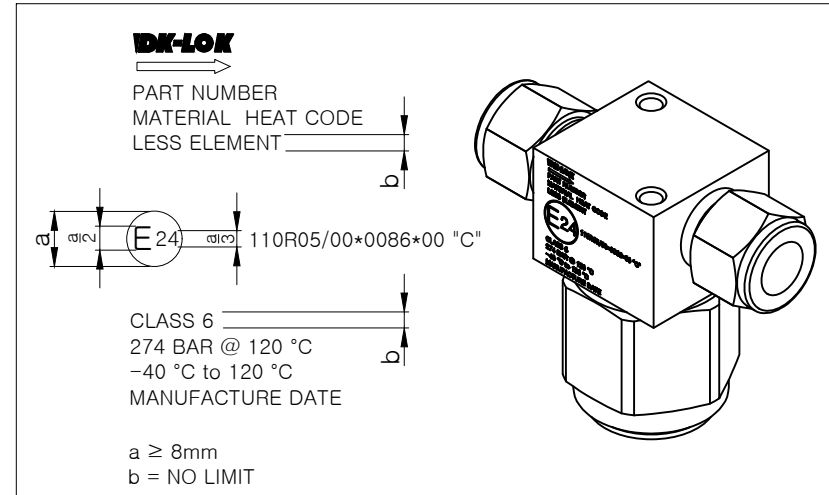

- * SPECIFICATION
1. DK-LOK TYPE : DK-LOK STANDARD
 2. NPT : ASME B1.20.1
 3. PT : ISO 7/1
 4. PF : ISO 228/1
 5. METRIC : ISO 261
 6. UNIFIED : ASME B1.1

VALVE SERIES	End Connections Type	SIZE
VC76 SERIES TEE FILTERS	DK-LOK	1/8", 1/4", 3/8", 1/2" 6mm, 8mm, 10mm, 12mm
	NPT, PT, PF, METRIC UNIFIED	1/8", 1/4", 3/8", 1/2"

***TECHNICAL DATA**

VALVE SERIES	MP PRESSURE RATING at 38°C(100°F)	TEMPERATURE RATING °C (°F)
VC76A, VC76B	6,000 psig (413 bar)	-28 to 482°C (-20 to 900°F)
VC76C	6,000 psig (413 bar)	

NO.	DESCRIPTION	MATERIAL	Q'TY
10	NUT	ASTM A 276 TYPE316	2
9	BACK FERRULE	ASTM A 479 TYPE316	2
8	FRONT FERRULE	ASTM A 479 TYPE316	2
7	RETAINER RING	ASTM A 276 TYPE316	1
6	NUT	ASTM A 276 TYPE316	1
5	SINTERED ELEMENT	STAINLESS STEEL 316	1
4	GASKET	ASTM A240 TYPE316(SILVER PLATED)	1
3	SPRING	STAINLESS STEEL 302	1
2	CAP	ASTM A 276 TYPE316	1
1	BODY	ASTM A 276 TYPE316	1

APPROVED	DESIGNED	TITLE
<i>S.H. Cho</i>	<i>X.H. Lee</i>	VC76 SERIES TEE FILTERS
REVIEWED		
SCALE	N/S	
DATE	2023.01.27	
DWG. NO.	VC76 SERIES (ECER110)	 Fittings & Valves

Annex 3 – DK-Lok Filter test samples

DK-Lok Corporation / DK-Lok Filter

Annex 3 of Test Report 23-00023-IS-MUC-00		
Type	Variant(s)	Test samples (3 units in each configuration)
DK-Lok CNG Filter	VC76 Series	- VC76A 1/4" DK-Lok - VC76B 8mm Dk-Lok - VC76C 10mm DK-Lok

The non-metallic materials tested and approved for the CNG DK-Lok Filter Variant(s) listed above are the following:

1. NBR N8614AA, 90 +/-5 Shore A, manufactured by GE MAO Rubber Industrial Co., LTD
2. HNBR H7000AA, 70 +/-5 Shore A, manufactured by GE MAO Rubber Industrial Co., LTD
3. EPDM E7050-AA, 70 +/-5 Shore A, manufactured by GE MAO Rubber Industrial Co., LTD
4. KETRON PK1000, >100 HRM, manufactured by Mitsubishi Chemical Advanced Materials Korea, LTD
5. PTFE TF1641, >56 HRD, manufactured by 3M Advanced Materials Division
6. ITAflon IT-1-10S, >60 HRD, manufactured by ITAflon S.r.l.

Annex 4 – DK-Lok Filter catalogs



~~V73 Series In-Line Filters~~ V73 is not in the approval scope
V76 Series Tee Filters

No .V 736 -10
 MAR.2023

Pressure Rating up to 3000 psig (206 bar), 6000 psig (413 bar)

Features

- Traps fine contamination to maintain system purity
- Gas and liquid filtration
- Standard micron filtering ranges
- Sintered Elements : 0.5, 2, 7, 15, 60 and 90 micron
- Strainer Elements : 40,140,230 and 440 micron
- Replaceable SS316 sintered and strainer elements
- SS316 and Brass body construction
- Choice of reliable DK-Lok, NPT & ISO pipe end connections
- Heat Code Traceability

V73 Series In-line Filters

- In-line filters are applicable where space is limited and elements don't have to be replaced often.
- Compact in-line design with large filtration area
- Maximum working pressure 3,000 psig @100°F(206 bar @38°C)

V76 Series Tee Filters

- Filter Element replaceable with the valve in-line.
- Safety union bonnet design for high pressure rating
- Optional Bypass for sampling or purging of process fluid.
- Maximum working pressure 6,000 psig @100 °F(413 bar @38°C)

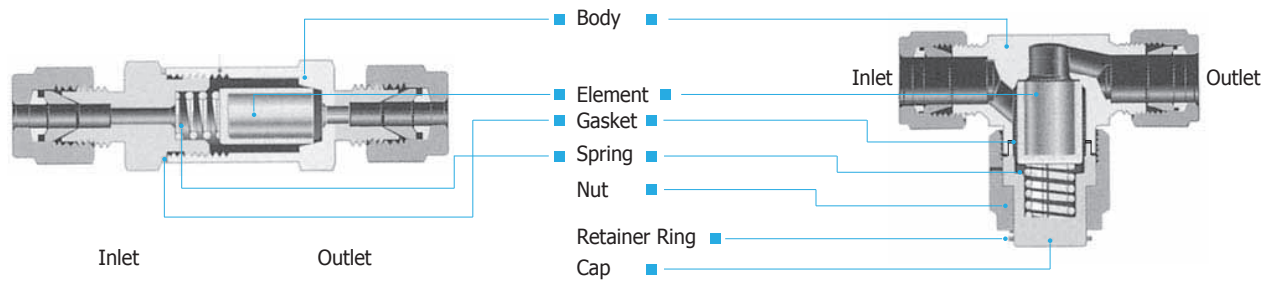

Materials of Construction

Component	V73 Series		V76 Series	
	Grade/ASTM Specification			
Body	SS316 / A276	Brass / B16	SS316 / A276	Brass / B16
Nut	-	-	SS316 / A276	Brass / B16
Cap	-	-	SS316 / A276	Brass / B16
Retainer Ring	-	-	Stainless Steel	
Element	SS316 (Sintered, Strainer)			
Spring	SS302			
Gasket	SS316 / A240 silver plated			

Wetted components are listed in blue.

Filtration Definitions

- **Filter Element :**
The component within the filter which traps media contamination.
- **Filtration Area :**
The actual surface area of the filter element available to trap contamination.
- **Micron :**
A unit of measure to describe the mean pore diameter of the filter element or the mean particle diameter of media contamination. One micron = 0.001mm or 0.00004 inch

V76 Series Tee Filter CNG Certifications

Certificates	ECER110	ANSI / CSA NGV 3.1:20	ISO 15500-18:2016
Certificate No	E24 110R05/00*0086*00	72160895-NGV 3.1	72160895-ISO 15500-4
Classification	Class 6	CNG-Filter	CNG-Filter
Temperature	-40°C to +120°C (-40°F to 250°F)	-40°C to +120°C (-40°F to 250°F)	-40°C to +120°C (-40°F to 250°F)
Pressure	W. P 274 bar @ 120°C	S. P 273 bar @ 21°C	W.P 274 bar @ 120°C

Sintered Elements Technical Information

- Stainless steel 316 sintered
- High heat resistance and thermal stability up to 1,500°F(815°C)
- High permeability with low-pressure drop.
- Shape-stability with self-supporting structural elements
- Suitable for compression, vibration, and high impulse pressures.
- Precise filtration because pore size and distribution are exact and uniform.
- Chemical resistance against acids and caustic solutions in various ranges of pH.

Element Designator	Nominal Pore Size, µm	Pore Size Range, µm	Element Porosity	Cv Factor	Max. Pressure Differential Across Clean Filters at 70°F (21°C)
05	0.5	0.5 - 2	17%	0.046	1160 psig (80.0 bar)
2	2	1 - 4	22%	0.056	
7	7	5 - 10	27%	0.12	
15	15	11 - 25	36%	0.13	
60	60	50 - 75	44%	0.38	
90	90	75 - 110	45%	0.50	

Element Replacement

- The sintered elements don't permit the contaminants in the gas and liquid to pass through the elements when they are bigger than the pore size of micron.
 - Contaminants are trapped by element pores and it results in pressure buildup.
 - Contamination comes earlier when flow volume is high and media is not clean.
 - The filtering elements need to be replaced for minimum pressure drop as well as system purity.
- Note :** Clean filter valve components whenever the element is replaced.

V73 Series In-line Filters

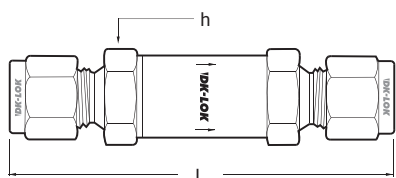

Flow Capacities

Filter Series	Nominal Pore Micron	Pressure Drop		
		20 psi	60 psi	120 psi
Water GPM @70°F (21°C)				
73A Series	05	0.01	0.44	0.13
	2	0.11	0.26	0.44
	7	0.14	0.33	0.53
	15	0.17	0.39	0.64
	60	0.21	0.55	0.77
	90	0.28	0.55	0.66
73B Series	05	0.06	0.19	0.32
	2	0.34	0.94	1.42
	7	0.57	1.42	2.19
	15	0.71	1.42	2.30
	60	1.27	3.61	5.04
	90	1.70	4.60	6.68
73C Series 73D Series	40,140,230,440	2.40	6.14	8.54
	05	0.13	0.44	0.83
	2	0.37	1.20	1.75
	7	0.91	2.41	3.83
	15	1.19	2.85	4.49
	60	2.83	7.34	10.95
73C, 73D	90	3.25	8.32	12.05
	40,140,230,440	5.00	15.40	19.40

Ordering Information and Dimensions

Basic Ordering Number	End Connections Inlet and Outlet	Orifice inch (mm)	Dimensions. mm (in.)	
			L	H
V73A-	D-2T- 1/8 in. DK-Lok	0.09 (2.4)	59.7(2.35)	9/16
	F-2N- 1/8 in. Female NPT		54.9(2.16)	
	D-3M- 3mm DK-Lok		60.5(2.38)	
V73B-	D-4T- 1/4 in. DK-Lok	0.19 (4.7)	74.9(2.95)	3/4
	M-4N- 1/4 in. Male NPT		68.3(2.69)	
	F-4N- 1/4 in. Female NPT		72.9(2.87)	
V73C-	D-6M- 6mm DK-Lok	0.28 (7.1)	75.2(2.96)	1
	M-8N- 1/2 in. Male NPT		81.3(3.20)	
V73D-	D-6T- 3/8 in. DK-Lok	0.41 (10.3)	81.5(3.21)	1
	D-8T- 1/2 in. DK-Lok		88.6(3.49)	

Technical Information

Filter Series	Pressure Rating @100 °F (38 °C), psig (bar)		Temperature Rating, °F (°C)		Filtration Area in.² (mm²)	
	SS316	Brass	SS316	Brass	Sintered	Strainer
V73A	3000 (206)	3000 (206)	-20 to 900 (-28 to 482)	-20 to 300 (-28 to 148)	0.55(350)	-
V73B					1.30(830)	1.0(640)
V73C, V73D	2500 (172)	2000 (137)			2.0(1280)	1.7(1090)

V76 Series Tee Filters

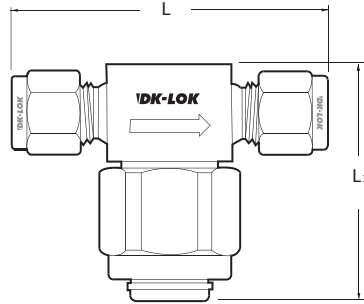

Top mounting

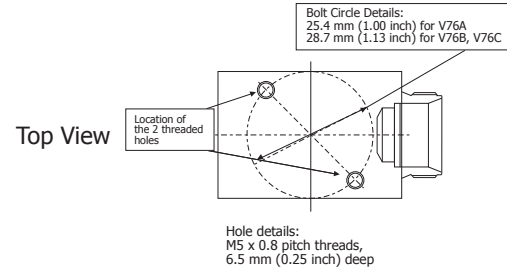

Ordering Information and Dimensions

Basic Ordering Number	End Connections Inlet & Outlet	Orifice mm (in.)	Dimensions, mm (in.)		
			L	L1	H
V76A	F-2N-	1/8 in. Female NPT	50.8(2.0)	47.5 (1.87)	-
	D-2T-	1/8 in. DK-Lok	57.7(2.27)		7/16
	D-4T-	1/4 in. DK-Lok	62.7(2.47)		9/16
	M-4N-	1/4 in. Male NPT	54.1(2.13)		1
	F-4N-	1/4 in. Female NPT	54.1(2.13)		-
V76B	D-6M-	6mm DK-Lok	62.5(2.46)	56 (2.2)	14mm
	D-6T-	3/8 in. DK-Lok	72.1(2.84)		11/16
	D-8M-	8mm DK-Lok	72.1(2.84)		1-1/8
V76C	M-6N-	3/8 in. Male NPT	60.5(2.38)	56 (2.2)	-
	D-10M-	10mm DK-Lok	72.6(2.86)		19mm
	D-12M-	12mm DK-Lok	77.2(3.04)		1-1/8
	D-8T-	1/2 in. DK-Lok	77.2(3.04)		7/8
	M-8N-	1/2 in. Male NPT	69.9(2.75)		-

All dimensions shown are for reference only and are subject to change. Dimensions with DK-Lok nuts are in finger-tight position.

Technical Information

Filter Series	Pressure Rating @100 °F (38 °C), psig (bar)		Temperature Rating, °F (°C)		Filtration Area in. ² (mm ²)	
	SS316	Brass	SS316	Brass	Sintered	Strainer
V76A, V76B	6000(413)	2000(137)	-20 to 900	-20 to 300	1.3(830)	1.0(640)
V76C	6000(413)	2000(137)	(-28 to 482)	(-28 to 148)	2.0(1280)	1.7(1090)

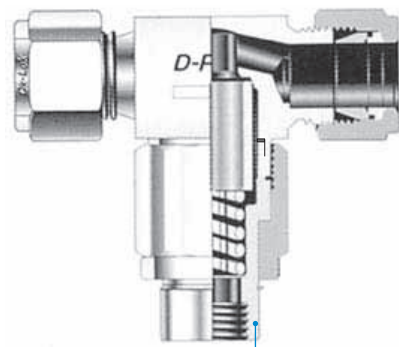

By-pass port

By-pass port of female 1/8 in. or 1/4 in. NPT is available for sampling and purging of process fluid. To use, replace the cap on Tee filter with the by-pass port.

Operation

Keep the cap downwards to prevent contaminants from entering the system during element replacement

Filter Series	Nom. Pore Micron	Pressure Drop		
		20 psi	60 psi	120 psi
Water GPM @ 70 °F(21 °C)				
V76A-F-2N V76A-D-2T	05	0.06	0.19	0.32
	2	0.11	0.26	0.44
	7	0.14	0.33	0.53
	15	0.17	0.39	0.64
	60	0.21	0.55	0.77
	90	0.28	0.55	0.66
40,140,230,440	0.28	0.55	0.66	
V76A-D-4T V76A-M-4N V76A-F-4N	05	0.06	0.19	0.32
	2	0.34	0.94	1.42
	7	0.57	1.42	2.19
	15	0.71	1.42	2.30
	60	1.13	2.96	4.27
	90	1.56	3.72	5.37
40,140,230,440	1.70	4.60	6.13	
V76B Series V76C Series	05	0.13	0.44	0.83
	2	0.37	1.20	1.75
	7	0.91	2.41	3.83
	15	1.19	2.85	4.49
	60	2.12	5.26	7.34
	90	2.40	6.02	8.33
40,140,230,440	2.60	7.50	10.80	

Ordering information

Select desired basic ordering number, element designator, option and body material listed below.

V76A-D-4T	-7		-BF2N	-S	
V76B-D-6T		-NE		-B	
Element			Filter with no element	By-pass	Body Material
Element Type	Element Designator	Nominal Micron	NE : Filter with no element Note : NE option is applicable to V76 series Tee filter only.	Nil : No By-pass option BF2N : 1/8 in. Female NPT BF4N : 1/4 in. Female NPT	S : SS316 B : Brass
Sintered	0.5	0.5			
	2	2			
	7	7			
	15	15			
	60	60			
Strainer	90	90			
	40	40			
	140	140			
	230	230			
	440	440			

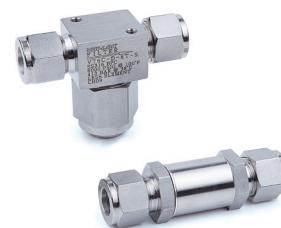

Field Assembly Kit

Element Kits

To order, select desired kit basic ordering number and element designator. Example : FE73A-05

Element Kit Basic Ordering Number		Element Designator	Nominal Pore Size, µm	Pore Size Range, µm	Kit applicable Filter Series	
Sintered	FE73A- FE73B- FE73C-	05	0.5	05 - 2	FE73A-	V73A
		2	2	1 - 4		
		7	7	5 - 10	FE73B-	V73B V76A
		15	15	11 - 25		
		60	60	50 - 75		
Strainer	FES76A- FES73C-	90	90	75 - 110	FE73C-	V73C, V73D V76B, V76C
		40	40	-	FES76A	V73B V76A
		140	140	-		
		230	230	-	FES73C-	V73C, V73D V76B, V76C
		440	440	-		

Gasket and Spring Kits

To order, select desired gasket or spring kit ordering number

Filter Series	Gasket Kit Ordering Number	Spring Kit Ordering Number	Kit applicable Filter Series
V73 Stainless Brass	9WSH-73A-S	9SPR-73A-2	V73A
	9WSH-73B-S	9SPR-73B-2	V73B
	9WSH-73C-S	9SPR-73C-2	V73C
	9WSH-73D-S	9SPR-73C-2	V73D
V76 Stainless Brass	76A-WSH-S	9SPR-76A-2	V76A
	76B-WSH-S	9SPR-76B-2	V76B / V76C

We reserve the right to change specifications stated in this catalog for our continuing program of improvement.

Safe Filter Selection

The Selection of a Filter for any application or system design must be considered to ensure safe performance. Filter function, Filter rating, material compatibility, proper installation, operation and maintenance remain the sole responsibility of the system designer and the user. DK-Lok accepts no liability for any improper selection, installation, operation or maintenance.

<p>IDK-LOK® Fittings & Valves www.dklok.com</p>	<p>IDK-LOK Corporation Mailing Address 7, Golden root-ro 129beon-gil, Juchon-myeon, Gimhae-si, Gyeongsangnam-do, South Korea (50969)</p>	<p>DK-Lok contact information Tel. (82) 55-338-0114 Fax. (82) 55-901-0143 E-mail : sales@dklok.com</p>	<p>For International customers Tel. (82) 55-338-0031/2 Fax. (82) 55-901-0142 E-mail : dklok@dklok.com</p>
--	---	--	---

Annex 5 – DK-Lok Filter service instructions

V76 Series Series Tee Filters, Service Instructions

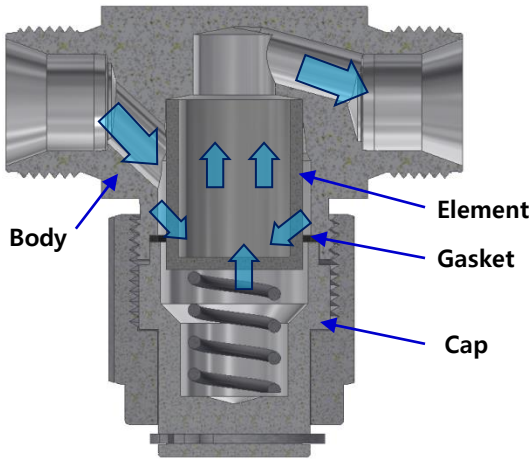

<Features>

- Traps fine contamination to maintain system purity
- Gas and liquid filtration
- Standard micron filtering ranges
- Sintered Elements : 0.5, 2, 7, 15, 60 and 90 micron
- Strainer Elements : 40,140,230 and 440 micron
- Filter Element replaceable with the valve in-line.
- Maximum working pressure 6,000 psig @100°F(413 bar @38°C)

<Filter Maintenance>

1. Isolate the cap from the Body.
2. Discard the old gasket & Element.

<Caution>
Center the gasket on the body seal surface.

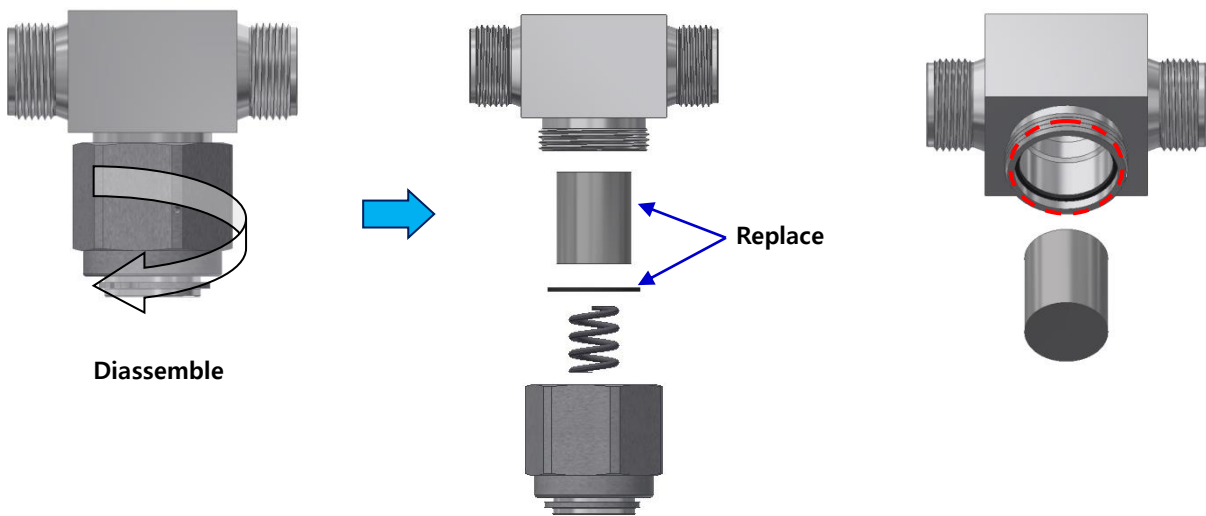

<Top mounting>

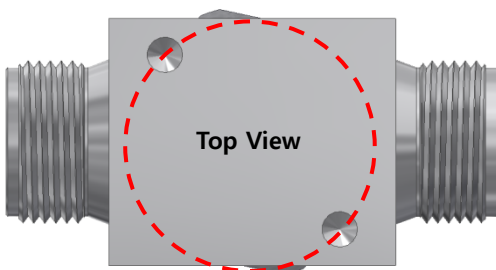

- Bolt hole details : M5 x 0.8 pitch thread(6.5 mm deep)
- Bolt Circle Details : 76A Series is 25.4 mm(1.0 inch)
76B&C Series is 28.7 mm(1.13 inch)
- Screws are 45 degrees from the center.

V76 Series Series Tee Filters, Service Instructions

< Tee Filters Installation >

* NPT, PT Thread Connector

- Wrap the PTFE tape onto the male threads.
 - : A thread tape acts as a lubricant allowing more thread engagement, prevent galling, and filling the gap between the crests and roots of mating threads to prevent formation of leak path.
- Thread the male threads onto the mating female threads until hand-tight and Using a wrench, tighten the male thread hex.

* Dk-Lok Tube Fitting Connector

1. prior to installation, make sure to have tube-end cut 90 degree, and remove burrs from inside and outside tube ends.
2. Use proper cutter and maintain a sharp cutting wheel on it.
3. Insert the tubing into the Dk-Lok tube fitting until the tubing end bottoms on the shoulder of the fitting body.
4. Make sure the nut figer-tight.
5. Scribe the nut at the 6 o'clock position and wrench-tighten the nut 1-1/4 turns to the 9 o'clock position, holding the body with a back up wrench.
6. Tighten the nut 3/4 turn to the 3 o'clock position for 1/16, 1/8 and 3/16 in.(2, 3 and 4mm)

< Good Practices for Operation of Tee Filters >

1. Use Screw protectors or dust caps on valve connector.
2. Align bodies and tube or pipe when install.
3. Installation at room temperature.
4. Support hanging tube or other equipment to prevent side load.